

1965 Bug Wiring Harness Kit

This wiring harness kit fits 6-volt and 12-volt Bug sedan and convertible models.

If your Bug has electrical upgrades, such as an alternator, or additional equipment, some modifications will be required.

Basic automotive electronic knowledge is essential for proper installation of this wiring harness. Thoroughly read these installation instructions and study the diagrams to familiarize yourself with the basic layout of your vehicle's electrical system.

Document the routing of the old wiring harness and sub-harnesses prior to removal. A digital camera is a useful tool for this step.

If your car was recently painted, you will need to address certain areas of the body/chassis in order to achieve proper electrical continuity. Use a file, sandpaper or emery cloth to remove paint from the mounting locations of the headlights, taillights, front directional indicator bulb holder, negative battery strap, transmission to chassis strap, etc. Use touch-up paint or nail polish to seal the surrounding areas of the connection to prevent corrosion.

Component List

- Main Harness (1)
- Dome Light Harness (1)
- Left Headlight Harness (1)
- Right Headlight Harness (1)
- Miscellaneous Wires/Sub Harnesses (18)
- Grommets (6)
- Headlight Plugs (2)
- 1-1 Connectors (7)
- 1-2 Connectors (3)
- Main Harness to Body Clips (2)

Installation

1. Disconnect negative cable from battery. Review the instructions, and identify the various sub-harnesses and supplemental wires.
2. Now the fun begins! Disconnect the main harness connections from their respective locations. Note that the main harness travels along the heater channel and the dome light harness travels through the roof member at the left-hand side of the Bug. With all the wires disconnected behind the dash push the main harness through the grommet in the trunk floor towards the interior of the car. Next, remove the rear seat bottom and left side rear door panel. Along the left heater channel on the interior of the car lift up the carpet where it meets the floor. Along this path you will find 2 clips holding the harness snug to the heater channel. Remove these with a screw driver releasing the harness. Attach a dragline onto the front portion of the wiring harness (fish tape or heavy cord material). Overlap the dragline and main harness for about one foot and use duct tape or plastic tape to attach the dragline securely to the main harness. Wrap the tape tightly as to create a strong, streamlined bundle. Next open the engine lid and remove any insulation material that may be present within the cavity located at the upper left corner of the compartment (where main harness exits). The main harness runs under the firewall sound deadner so you may want to remove the engine to gain better access to remove the sound deadner. Disconnect all the wires from the corresponding components. With the dragline securely attached to the old main harness, pull the harness from the rear as an assistant helps guide the dragline under the rear seat. .

With the old harness removed slide the supplied large 50mm grommet, part # 111971919, onto the tail end of the new main harness and up towards the middle of the loom making sure that the grommet is positioned with the open cup facing forward. Attach the rear of the new main harness onto the dragline under the rear seat in the same fashion as prior. Coat the new harness liberally with wire lube (surgical lube works well, KY Jelly, Astroglide, etc.) and pull the new harness into place from the rear while an assistant helps guide the harness from inside the left quarter panel. Be sure to keep lubricating the new harness as it is being fed while keeping the harness bundle as straight as possible. If the harness becomes stuck, do not force the issue. Reverse the procedure and observe the path of travel and remedy any obstacle. With the harness pulled into position use the supplied 2 new clips to attach the new harness to the side of the heater channel. Feed the front end of the harness through the underside of dash into the trunk area using the new grommet supplied, part # 111971907 See diagram on page (5) for proper connections on the main harness.

2. Remove the dome light from the roof, and disconnect the wires. Remove the wires from each dome light switch located behind each door jamb, and remove the red wire from the fuse box. Attach a dragline onto the wires at the roof opening and carefully feed the dragline through the slot, while an assistant pulls the dome light harness from the front.

Attach the dragline onto the new dome light harness and feed through the front, while an assistant gently pulls the dragline at the roof opening.

3. Install new left and right headlight harness, see diagram on page (6). You may want to lift out the fuel tank for this step to gain easier access. When routing the wires through the rubber headlight wiring conduit, use lubricant to ease the wires through. If your wiring conduits are not in satisfactory condition, these are available separately (part # 111941185). Use the supplied headlight plugs and refer to the diagram on page (6) to correctly locate the wires into the plug.

Place the supplied 1-1 connector onto the single black/red wire (fuse box side of the harness), and connect this wire to the black/red wire of the main harness. Use the supplied grommet # 111953549

and route the high/low switch, horn, and brake light wire bundles through journal in trunk (left side of the trunk, near the fuel tank). Use the supplied grommet # 111971911 and route the horn and brake light wire bundles through the firewall. Attach the brown wire to the tab located on the steering column.

Pay close attention to the parking light connections. The grey wire should connect to the center lug only. The lug located at the end is for ground, which typically is not required as the unit will ground to the assembly via the mounting screw. In the event a clean ground is not achieved (newly painted models, for example), use an 18-gauge wire and attach one end to this lug, and the other to terminal 31 of the headlamp plug. Install the headlight wires onto their respective location as per the diagram onto the supplied headlight plugs.

4. Connect previously installed dome light harness, see page (7) for connection locations.
5. Install miscellaneous supplemental wires, see page (8-9) for illustrations:
 - Attach high beam warning light wire (blue/white, 200mm length, both ends finished with female quick disconnect terminals) onto the proper bulb socket within the speedometer, and the other end to the fuse box as noted in the diagram.
 - Install left and right front turn signal wires. The left turn signal wire is a black/white wire, 1040mm in length, both ends finished with a female quick disconnect terminal. The right turn signal wire is a black/green wire, 1460mm in length, both ends finished with a female quick disconnect terminal. Install the 1-2 connectors onto the corresponding wires of the turn signal switch. Note that the single terminal side of the connector is the location for each of these wires, with the other two terminals reserved for the corresponding wires of the main harness, and turn signal switch.
 - Install taillight harnesses (three wires bundled in white conduit, 410mm length), see diagram on page (5). Install the 1-1 connectors and the 1-2 connector as outlined in the diagram onto the corresponding wires of the main harness. Connect each taillight harness to their respective positions as outlined within the diagram. Use the supplied grommets (center portion has a closed membrane, use knife to open small slice in center) to route each harness through the quarter panel.
 - Install license light harness (grey/red wire with black conduit, 1390mm length, each end finished with female quick-disconnect terminal), see diagram on page (5). The license light wire connects onto the 1-2 connector of the right taillight harness. Route the wire to the license light assembly while observing its proximity to the fan. Keep the slack of the wire as far away from the fan as possible.
 - Attach turn signal indicator wire (blue/green, 200mm length, both ends finished with female quick disconnect terminals) from the proper bulb socket within the speedometer, to terminal K of the turn signal relay. Please note that some modern and/or post production flashers refer to this terminal as L, or 49a. If using a 4-prong flasher relay, you will need to ground the flasher at terminal 31.
 - Attach turn signal switch input wire (black/green/white wire, attached to the turn signal switch, not included with this harness kit) to terminal S of the turn signal flasher relay. Please note that some modern and/or post production flashers refer to this terminal as 49a.
 - Attach instrument illumination wire from terminal 58b of the headlight switch to speedometer illumination bulb and fuel gauge illumination bulb, (grey/red wire, 180mm length, two wires total joined at one location, each end finished with female quick-disconnect terminal).

- Attach voltage regulator power wire (red, 900mm length, shielded in black PVC conduit, one end finished with an eyelet terminal) to the threaded post of the starter solenoid (terminal 30), and the other end to terminal B+ of the voltage regulator.
 - Attach parking light power wire from terminal 58 of the headlight switch, to the fuse box as noted in the diagram (grey wire, 255mm length, each end finished with female quick-disconnect terminal).
 - Attach headlight switch power wire from terminal 30 of the headlight switch, to the fuse box location as noted in the diagram (red wire, 250mm length, each end finished with female quick-disconnect terminal).
 - Attach ignition switch power wire from terminal 30 of the ignition switch, to the fuse box location as noted in the diagram (red wire, 150mm length, end finished with female quick-disconnect terminal).
 - Attach speedometer bulb cluster power wire from the fuse box location as noted in the diagram (large wire), to terminal 15 of the ignition switch (large wire). Attach the small wire onto the speedometer bulb cluster located at the bottom of the speedometer (black wire, two wires total joined at one location, one small and one large, each end finished with female quick-disconnect terminal).
 - Attach windshield wiper motor wires from wiper motor, to wiper switch: Terminal 31b of wiper motor to terminal 31b of wiper switch (brown wire, 255mm length, each end finished with female quick-disconnect terminal). Terminal 54 of wiper motor to terminal 54 of wiper switch (black wire, 260mm length, each end finished with female quick-disconnect terminal). Terminal 54b of wiper motor to terminal 54b of wiper switch (black/purple wire, 255mm length, each end finished with female quick-disconnect terminal).
 - Attach horn ground wire from location on steering coupler (connector end), through the steering shaft and onto the horn ring (bar end) (brown wire, 1050mm length, one end finished with female quick-disconnect terminal, one end soldered).
 - Attach choke power wire from terminal 15 of the coil, to choke element located on the side of the carburetor (black wire, 480mm length, each end finished with female quick-disconnect terminal).
6. With installation now complete, double check all connections. Carefully connect battery and test each system for proper operation.

Main Harness

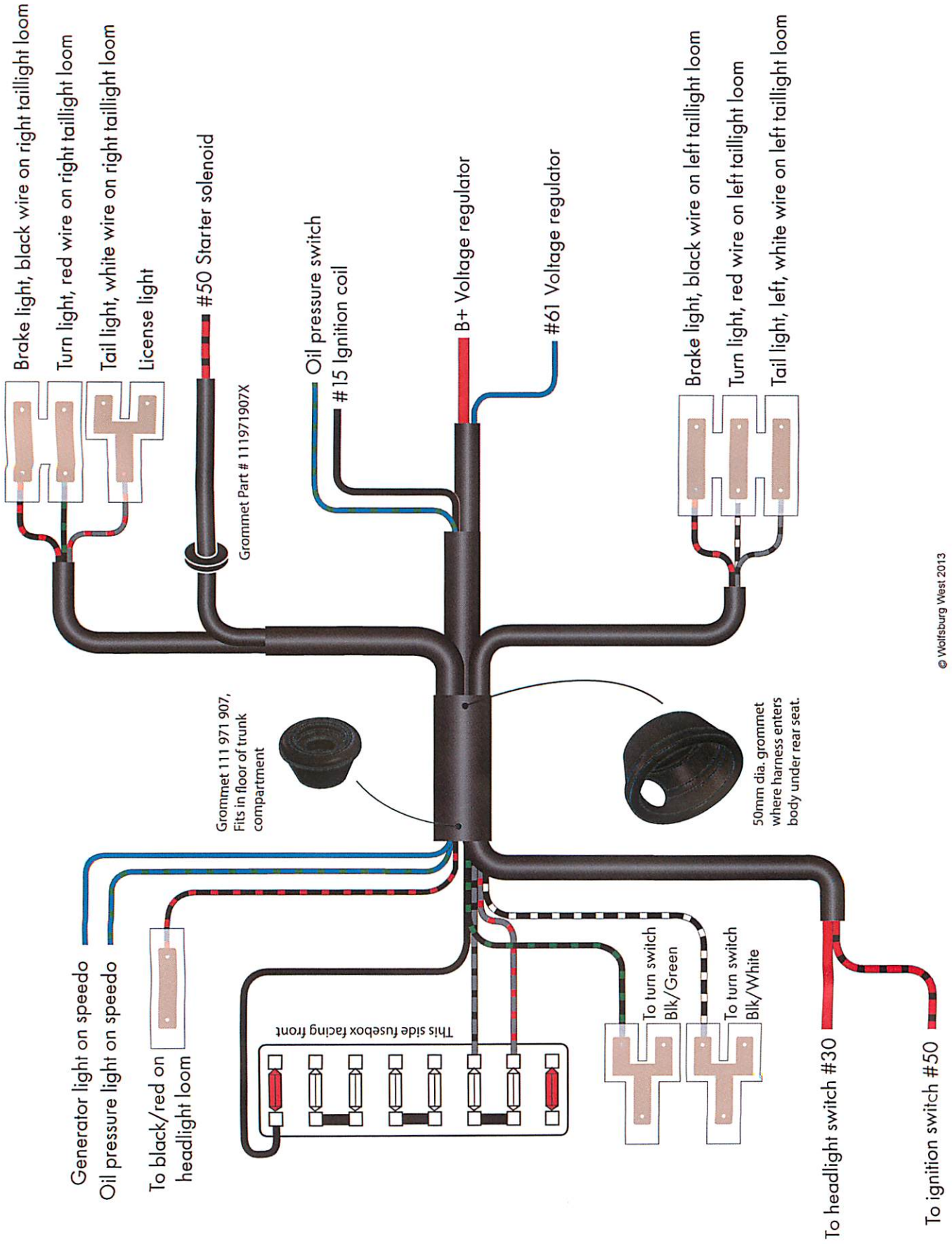

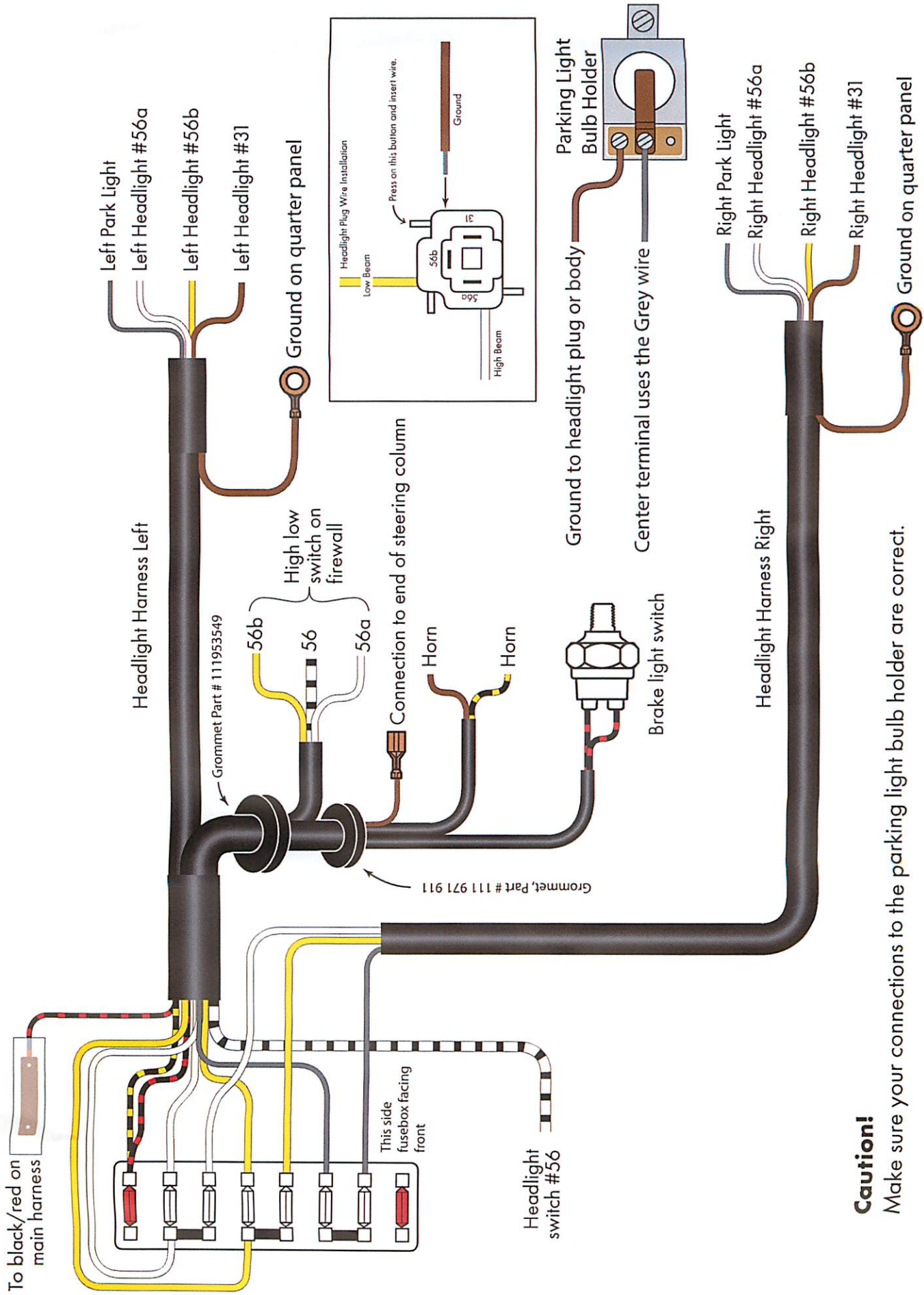

Caution!
Make sure your connections to the parking light bulb holder are correct.

Dome Light Harness

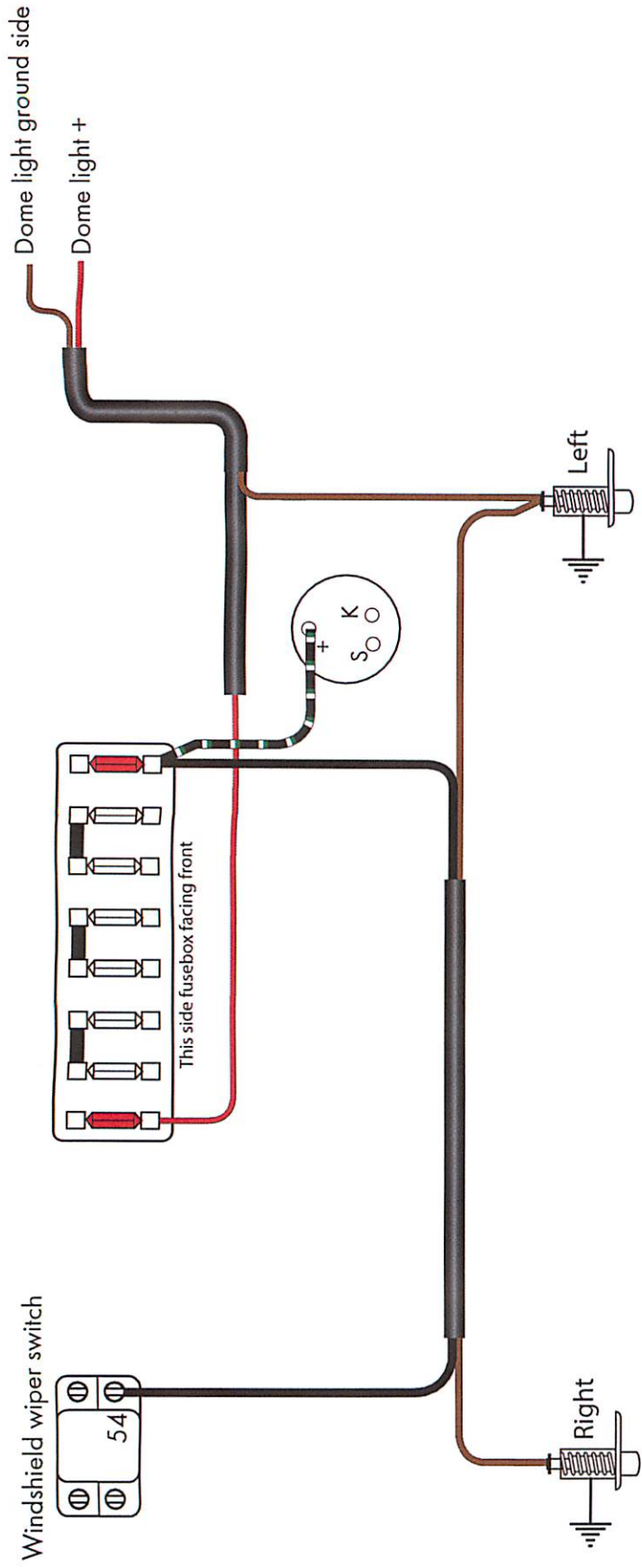

Miscellaneous Wires

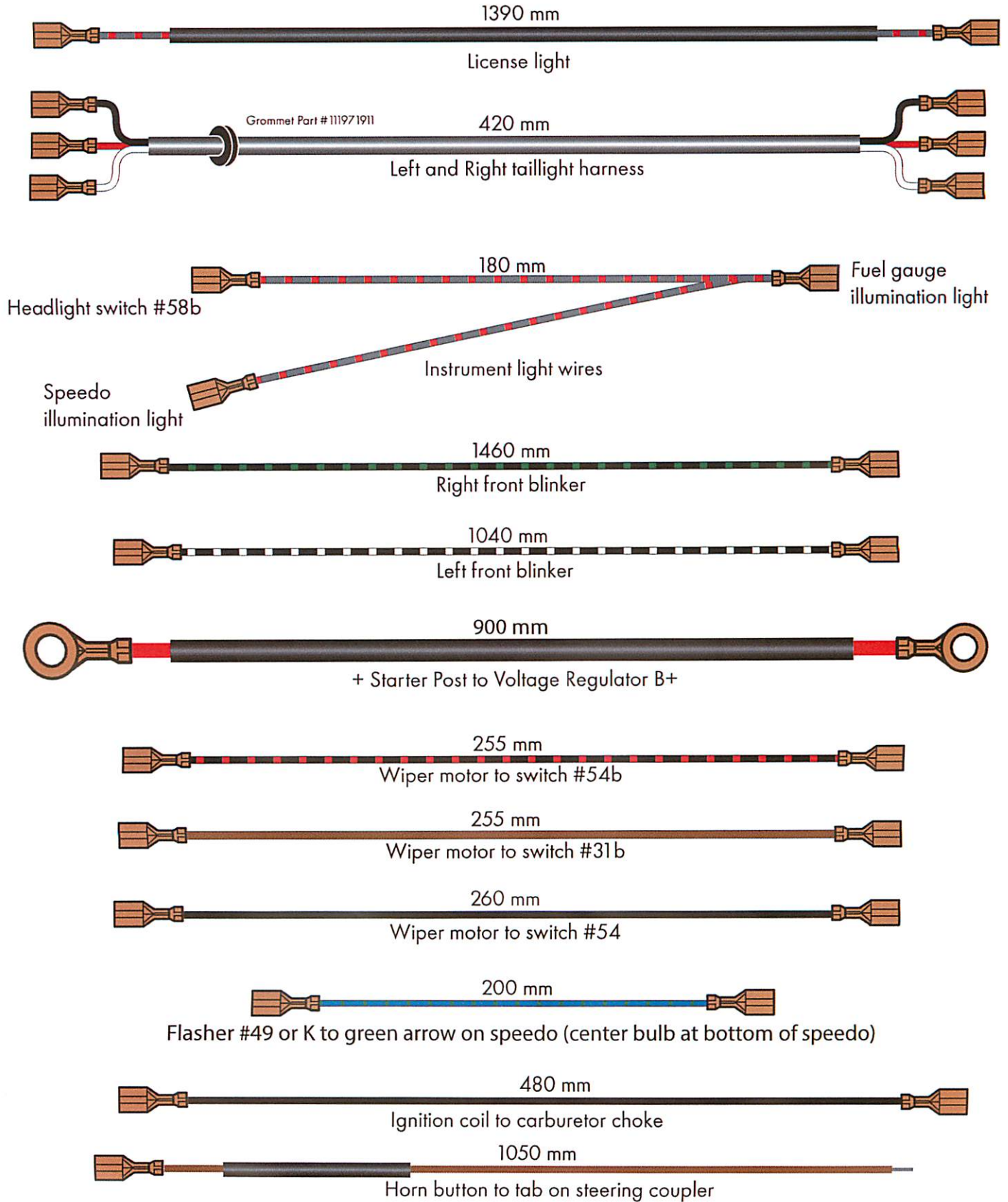

Miscellaneous Wires

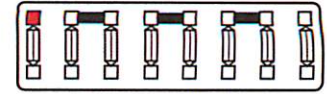
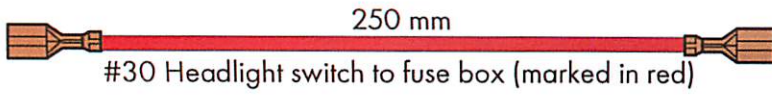

This edge facing front of car

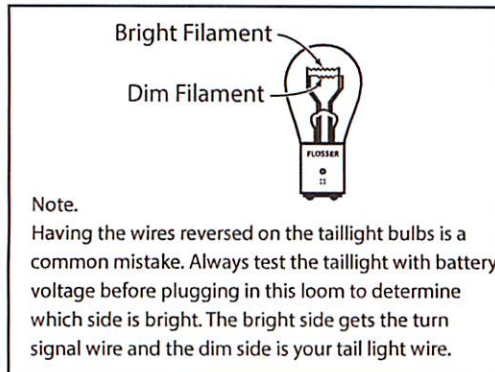
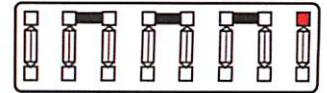
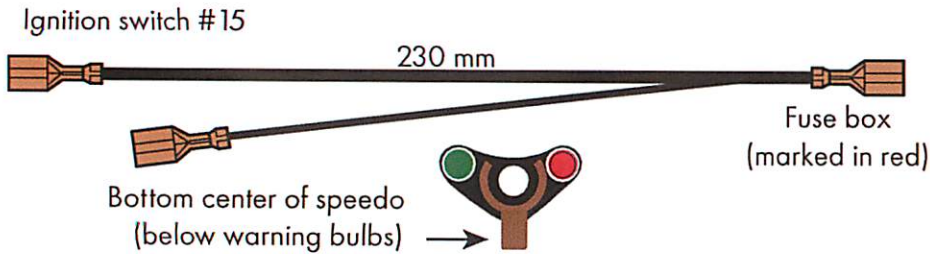
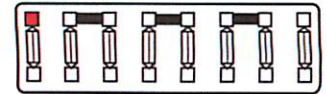
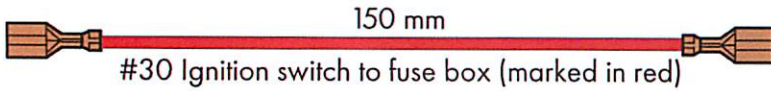
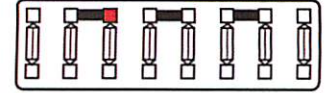
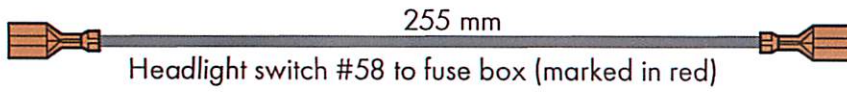
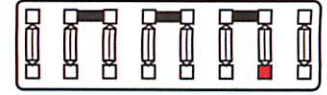
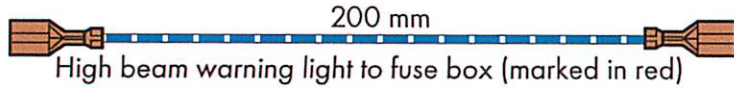

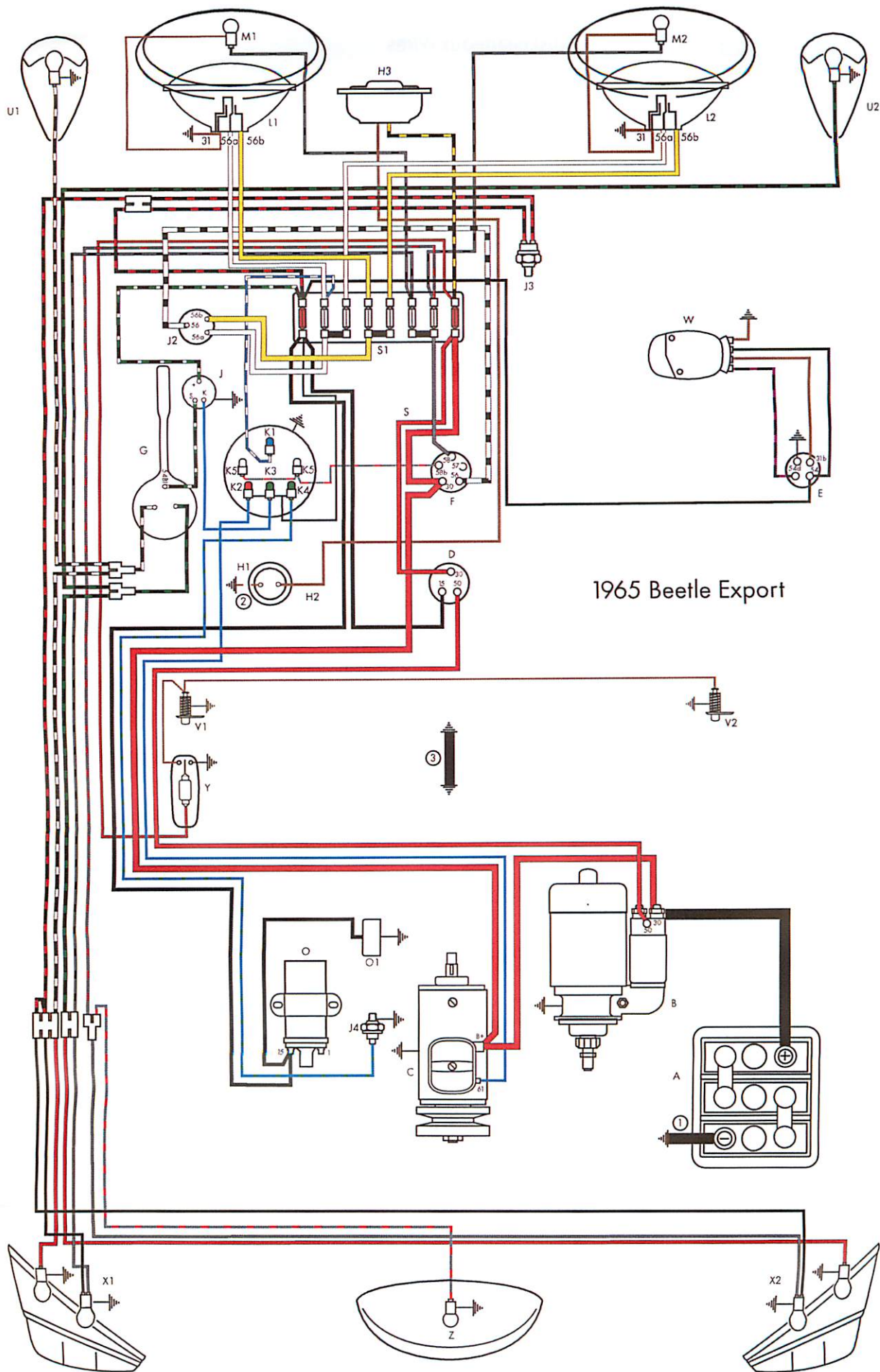

1965 Beetle Export

- A Battery
- B Starter
- C Generator
- D Starter/Ignition switch
- E Windshield wiper switch
- F Light switch
- G Turn indicator switch
- H3 Horn
- H1 Horn button
- H3 Horn brush
- J Flasher relay
- J2 Dimmer switch
- J3 Stop light switch
- J4 Oil pressure switch
- K1 High beam warning light
- K2 Generator warning light
- K3 Turn indicator warning light
- K4 Oil pressure warning light
- K5 Speedometer light
- L1 Sealed-beam unit, left
- L2 Sealed-beam unit, right
- M1 Parking light, left
- M2 Parking light, right
- O Coil
- O1 Automatic choke
- S1 Fuse box, 8 fuse
- U1 Turn indicator, front left
- U2 Turn indicator, front right
- W Windshield wiper motor
- X1 Stop/tail light, rear left
- X2 Stop/tail light, rear right
- Y Interior light
- Y1 Interior light switch, left
- Y2 Interior light switch, right
- Z License plate light

- ① Battery ground strap
- ② Steering column to steering box ground jumper
- ③ Chassis to transaxle ground strap