

### 1972-1973 Standard Beetle Wiring Harness Kit

This wiring harness kit fits 12-volt Bug sedan models.

If your Bug has electrical upgrades, such as an alternator, or additional equipment, some modifications will be required.

Basic automotive electronic knowledge is essential for proper installation of this wiring harness. Thoroughly read these installation instructions and study the diagrams to familiarize yourself with the basic layout of your vehicle's electrical system.

Document the routing of the old wiring harness and sub-harnesses prior to removal. A digital camera is a useful tool for this step.

If your car was recently painted, you will need to address certain areas of the body/chassis in order to achieve proper electrical continuity. Use a file, sandpaper or emery cloth to remove paint from the mounting locations of the headlights, taillights, front directional indicator bulb holder, negative battery strap, transmission to chassis strap, etc. Use touch-up paint or nail polish to seal the surrounding areas of the connection to prevent corrosion.

Please note that this harness kit does not include the wiring for the diagnostic test plug that you would find in the engine compartment. Also not included is the seat belt lock-out system or additional wiring needed if you have an autostick.

#### Component List

- Main Harness (1)
- Dome Light Harness (1)
- Headlight Harness (1)
- Brake Light Harness (1)
- Miscellaneous Wires/Sub Harnesses (34)
- Grommets (7)
- Headlight Plugs (2)
- 1-1 Connectors (15)
- 1-1 Male Connectors (13)
- 1-2 Connectors (1)
- 2-2 Connectors (2)
- Main Harness to Body Clips (2)
- Piggy back connectors (2)

## Installation

1. Disconnect negative cable from battery. Review the instructions, and identify the various sub-harnesses and supplemental wires.
2. Now the fun begins! Disconnect the main harness connections from their respective locations. Note that the main harness travels along the heater channel and the dome light harness travels through the roof member at the left-hand side of the Bug. With all the wires disconnected behind the dash push the main harness through the grommet in the trunk floor towards the interior of the car. Next, remove the rear seat bottom and left side rear door panel. Along the left heater channel on the interior of the car lift up the carpet where it meets the floor. Along this path you will find 2 clips holding the harness snug to the heater channel. Remove these with a screw driver releasing the harness. Disconnect the wires from the voltage regulator. Next open the engine lid and remove any insulation material that may be present within the cavity located at the upper left corner of the compartment (where main harness exits). The main harness runs under the firewall sound deadener so you may want to remove the engine to gain better access to remove the sound deadener. Disconnect all the wires from the corresponding components. Attach a dragline onto the rear portion of the wiring harness (fish tape or heavy cord material). Overlap the dragline and main harness for about one foot and use duct tape or plastic tape to attach the dragline securely to the main harness. Wrap the tape tightly as to create a strong, streamlined bundle. With the dragline securely attached to the old main harness, pull the harness from the rear as an assistant helps guide the dragline under the rear seat. .  
With the old harness removed slide the supplied large 50mm grommet, part # 111971919, onto the tail end of the new main harness and up towards the middle of the loom making sure that the grommet is positioned with the open cup facing forward. Attach the rear of the new main harness onto the dragline under the rear seat in the same fashion as prior. Coat the new harness liberally with wire lube (surgical lube works well, KY Jelly, Astroglide, etc.) and pull the new harness into place from the rear while an assistant helps guide the harness from under the rear seat. Be sure to keep lubricating the new harness as it is being fed while keeping the harness bundle as straight as possible. If the harness becomes stuck, do not force the issue. Reverse the procedure and observe the path of travel and remedy any obstacle. With the harness pulled into position use the supplied 2 new clips to attach the new harness to the side of the heater channel. Feed the front end of the harness through the underside of dash into the trunk area using the new grommet supplied, part # 111971907 See diagram on page (5) for proper connections on the main harness.
3. Remove the dome light from the roof, and disconnect the wires. Remove the wires from each dome light switch located behind each door jamb, and remove the red wire from the fuse box. Attach a dragline onto the wires at the roof opening and carefully feed the dragline though the slot, while an assistant pulls the dome light harness from the front.  
Attach the dragline onto the new dome light harness and feed through the front, while an assistant gently pulls the dragline at the roof opening. Connect harness per diagram on page (7)
4. Install new headlight harness, see diagram on page (6). When routing the wires through the rubber conduits make sure to include the 580mm long brown ground wires and use lubricant to ease the wires through. Use the supplied headlight plugs and refer to the diagram on page (6) to correctly locate the wires into the plug. Route the horn wire bundle through journal in trunk (left side of the trunk, next to brake tubes). Install the appropriate push-on connectors to the harness. (see page 6)
5. Install brake light switch harness . Route the harness through the slot in the body on the drivers side of the fuel tank . Connect to the T3 plug on the headlight harness, page (7) matching corresponding colors.
6. Install left and right front turn signal/park light harnesses. Use the illustration on page (8) for correct

installation. You want to make sure that you connect the black wire to the brighter side of the bulb (see note in upper corner of page (8) for more info).

7. Ignition Switch and Steering Column Harnesses. From the inside of the car plug the harnesses into the underside of the dash next to the steering column. Route the turn signal/wiper harness through the hole on the left side of the column and the ignition switch harness through the hole on the right side of the column. Finish installation using the diagram on page (9). Don't forget to lube the grommets before installation.

8. Install miscellaneous supplemental wires, see page (10-12) for illustrations:

**Its best if you have the dash switches removed from the dash with the terminal identification in clear view when installing the balance of dash wiring.**

- Install taillight harnesses (5 wires bundled in white conduit, 525mm length), see diagrams on pages (10 & 5). Install the 1-1 connectors and the 1-2 connector as outlined in the diagram onto the corresponding wires of the main harness. Connect each taillight harness to their respective positions as outlined within the diagram. Use the supplied grommets (center portion has a closed membrane, use knife to open small slice in center) to route each harness through the quarter panel.

- For the back-up lights follow the diagram on page (8) to install the necessary wires.

- Install license light harness (grey and brown wires in black conduit, 1250mm length) , see diagram on page (10). The grey license light wire connects onto the 1-2 connector of the right taillight harness. Route the wire to the license light assembly while observing its proximity to the fan. Keep the slack of the wire as far away from the fan as possible. Use two of the 1-1 male connector sleeves to plug into license light.

- Attach the dash ground wire harness (brown wire many connectors) using the diagram shown on page (12).

- Attach misc. power wire harness using the diagram shown on page (7).

- Attach choke power wire from terminal 15 of the coil, to choke element located on the side of the carburetor and to idle shut off valve. (black wire, 425mm length, one end finished with female quick-disconnect terminal and opposite end finished with short black wire with quick disconnect ends).

- Install the heavy red wire in the PVC sleeve, 920mm long between the starter, terminal 50 through the rear of the floor pan on the drivers side using the supplied grommet and using a 1-1 connector connector to the remaining thick red wire out of main harness at the voltage regulator.

- If you will be running the ignition key buzzer use the three wires at the bottom of page (12) to complete this circuit.

- We have supplied an extra wire to use on high/low beam relays that have a #30 terminal. You may not need this.

This completes the installation. Review your work to insure that you have not crossed any wires. Reconnect the battery cables and check all the electrical components for proper operation.

Installation of male push-on connector sleeve.

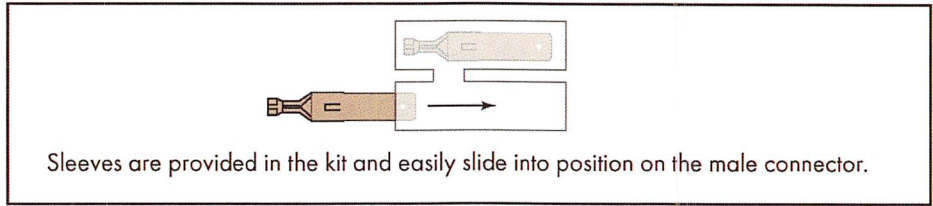

Within the following pages we use the diagram below with a red marking to indicate the exact position of the wire within the relay panel. In this example the wire would be running to the High Beam Relay at the terminal marked in red. This relay panel sits on top of the fuse box.

View of fuse box relay panel, relay side.

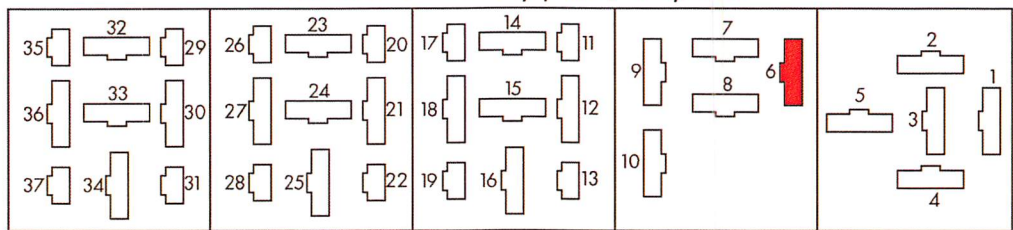

Ignition Buzzer

High Beam Relay Turn Signal Relay

Note: If you're Beetle has an alternator with a remote regulator this wiring harness will not fit without making modifications beyond the scope of these instructions. Alternators with remote regulators are identified by having a 3 position push-on terminal connection. Alternators with an internal regulator have 1 push-on and 1 stud for its output. See the illustrations below if your not sure.

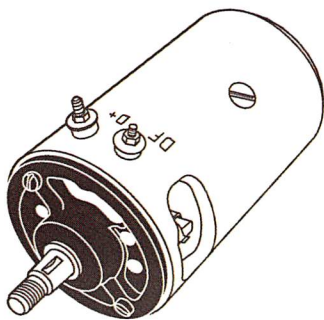

Generator

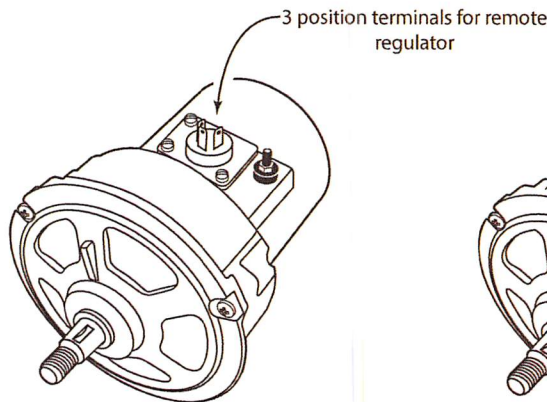

Alternator, accepts remote regulator

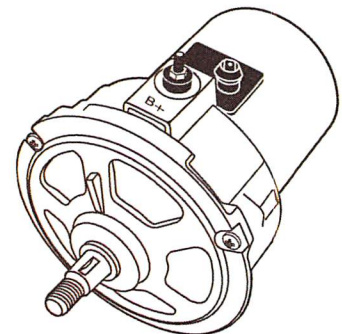

Alternator, with internal regulator

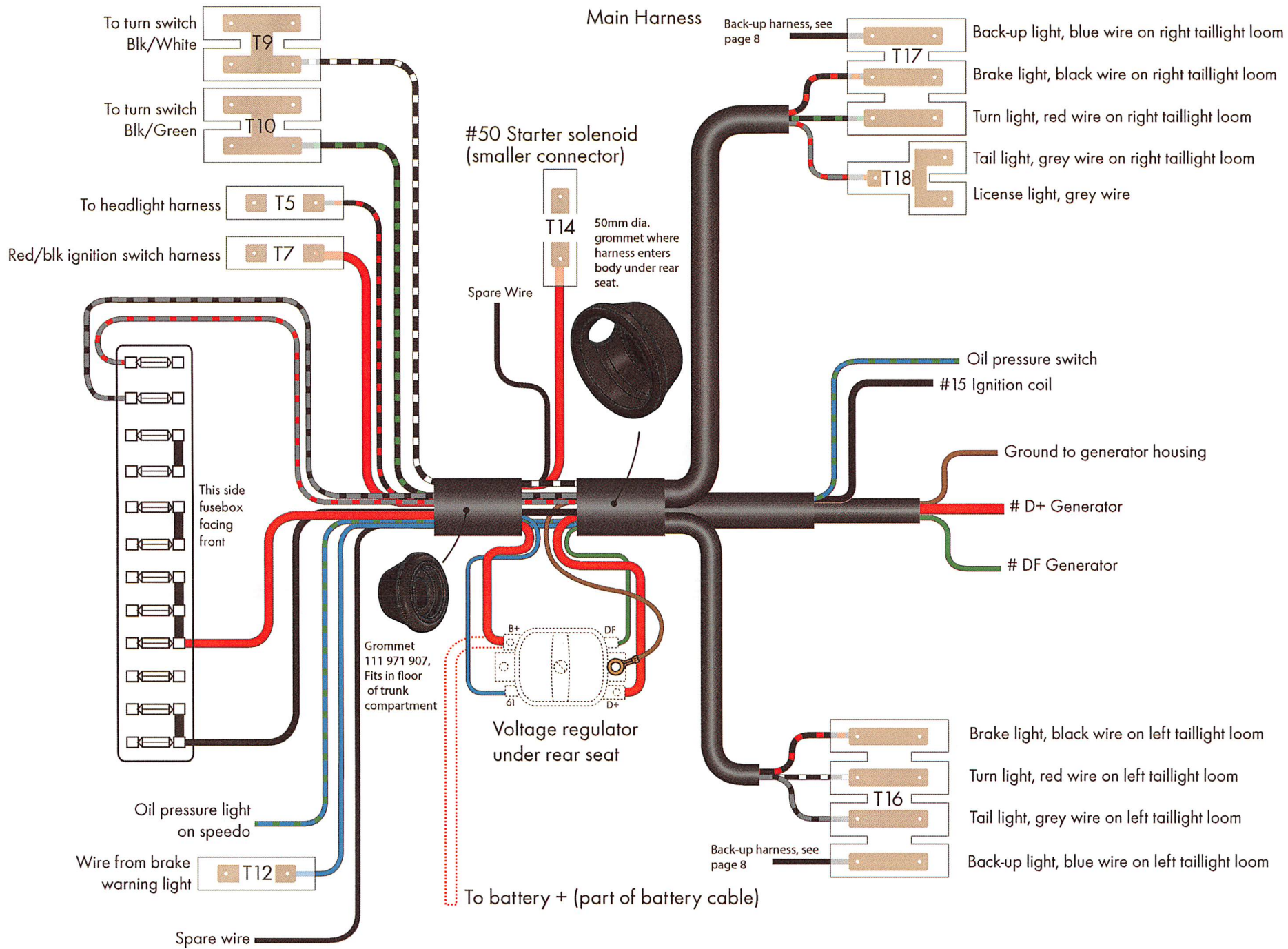



# Headlight Harness

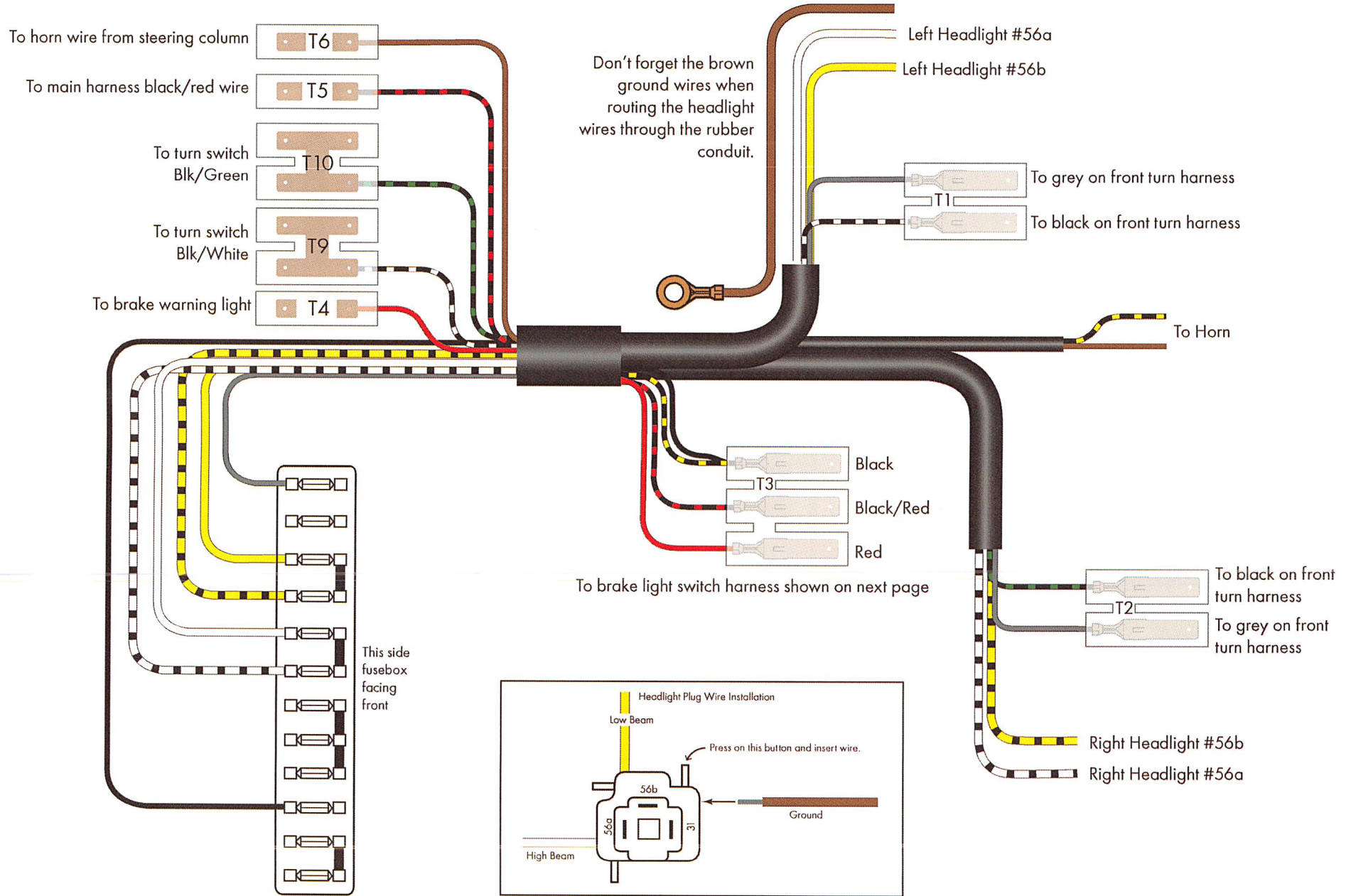

### Brake Light Switch Harness

To corresponding wires on headlight harness, connector T3.

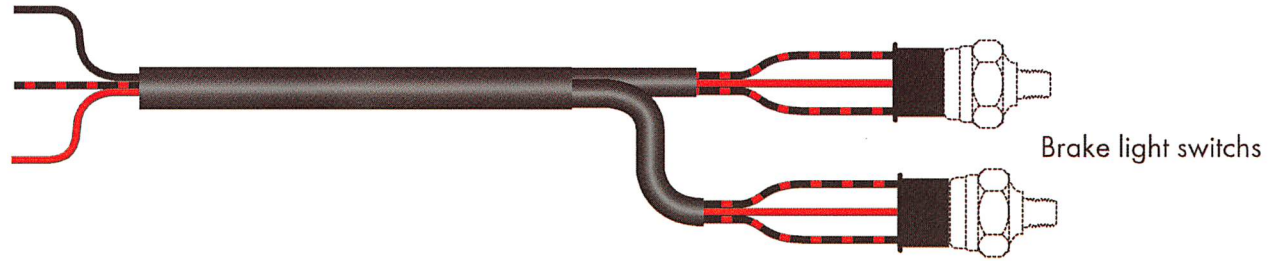

### Dome Light Harness

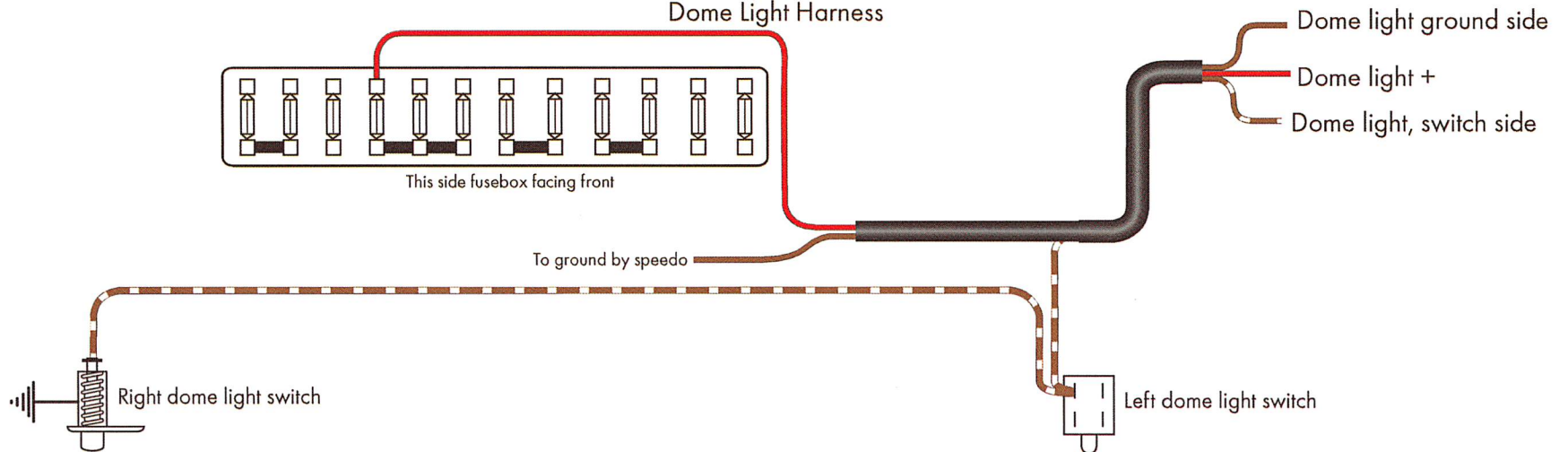

### Misc. Power Harness

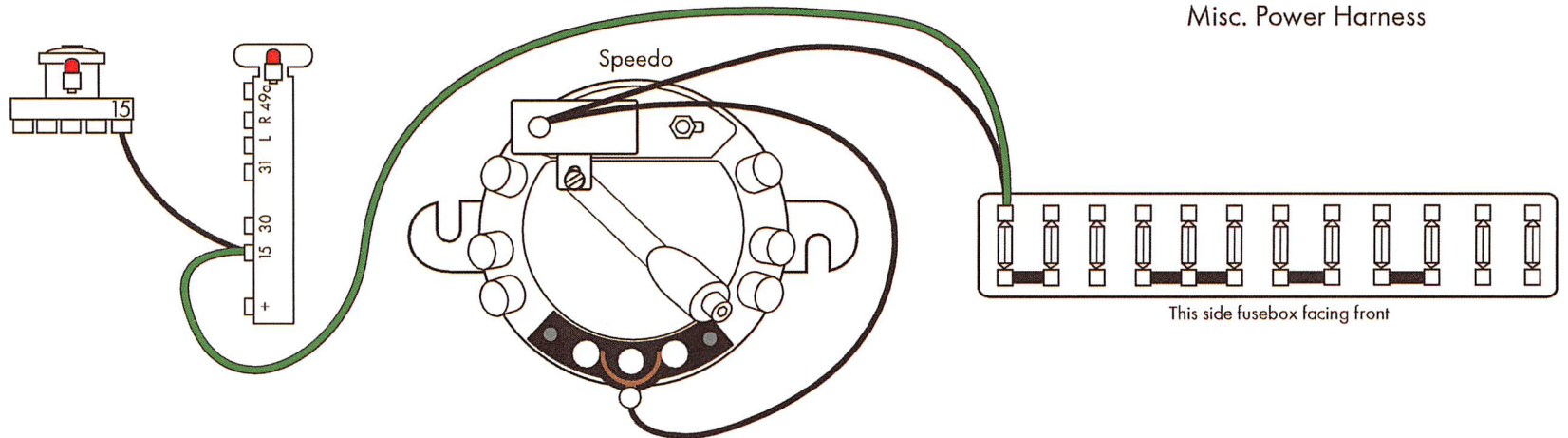

## Front turn signal/park light harnesses

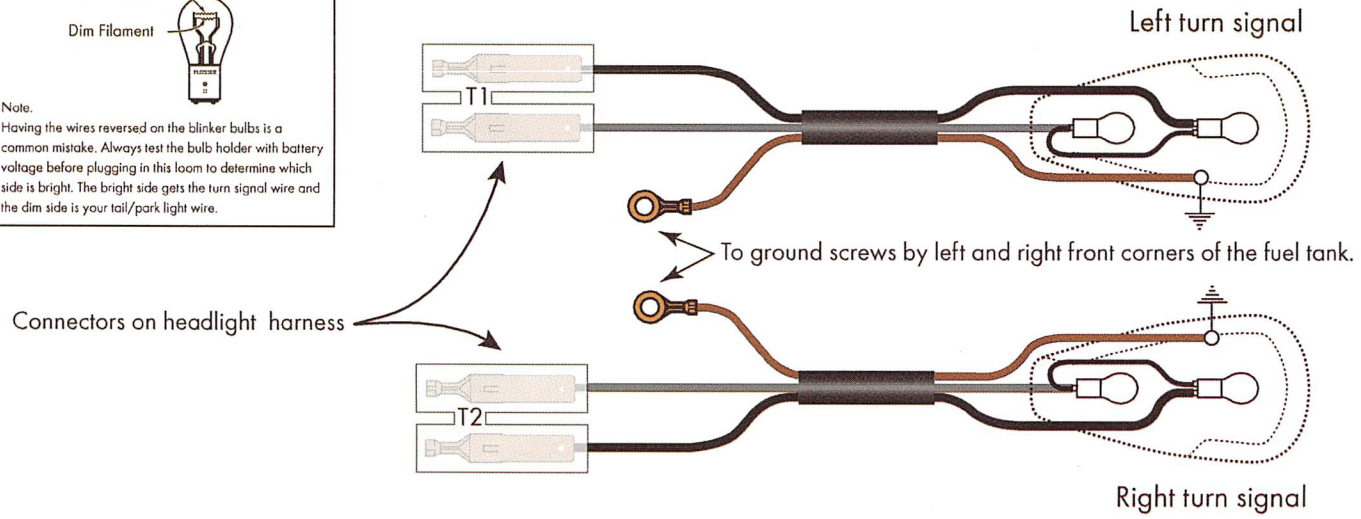
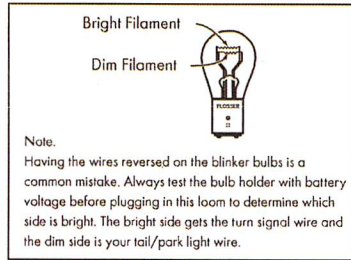

## Back-up Light Harness

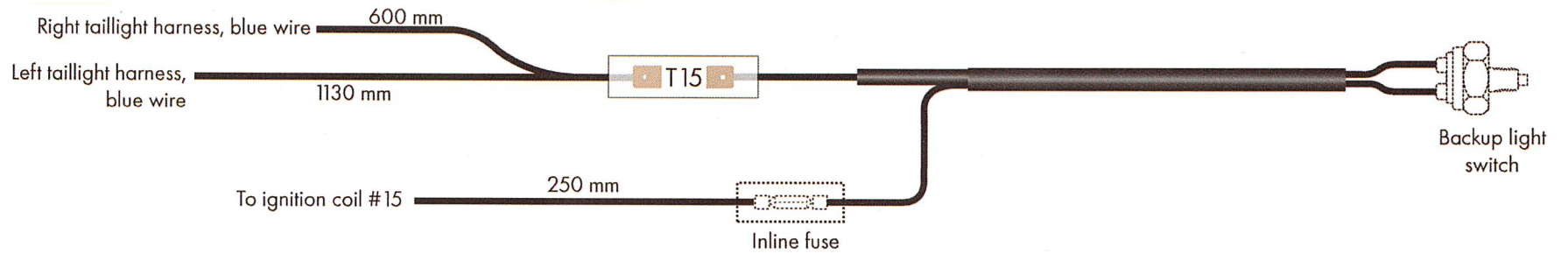



## Steering Column Harness

To corresponding wire colors from wiper motor, connector T13. Connector T13 and wiper motor wires are part of the wiper motor and not included.

To fuse box (marked in red)

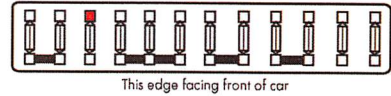

- Connector T10, Right Turn, main harness
- To connector T11, see top page 11
- Connector T9, Left Turn, main harness
- Connector T6, Horn, headlight harness
- To ground by speedo

Grommet  
Part number 311 971 907

This connector has a lock tab and plugs into the fuseblock at the position shown in red.

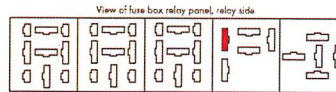

## Steering Column Harness

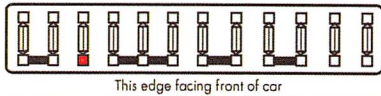

Connector T8, door switch, if running door buzzer

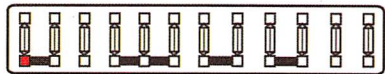

To connector T7, solid red wire, on main harness

Grommet  
Part number 311 971 909

This side to license light.  
Brown is ground.

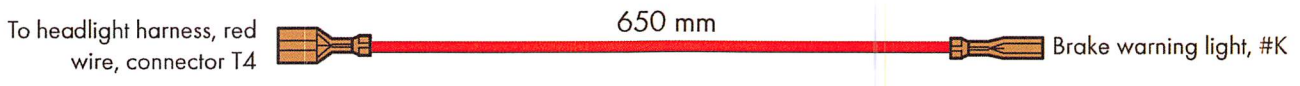
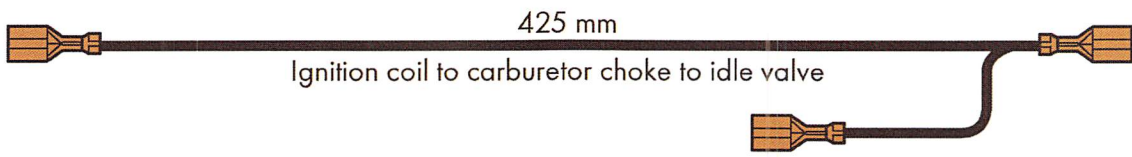
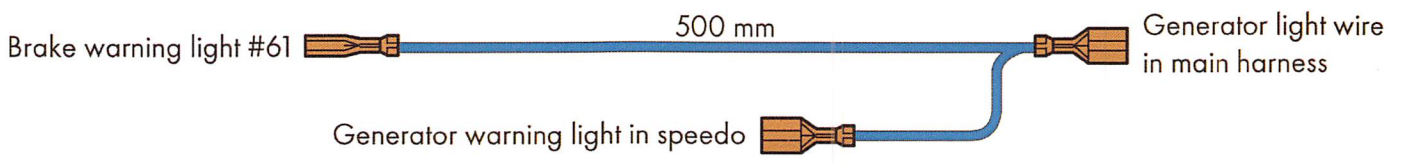
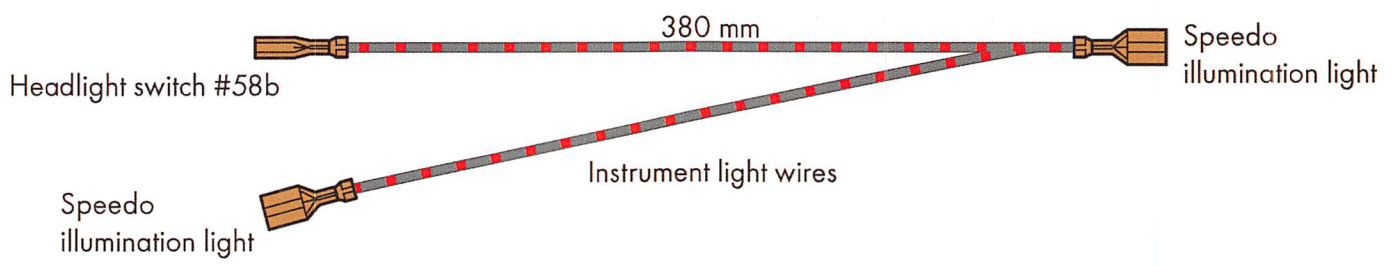
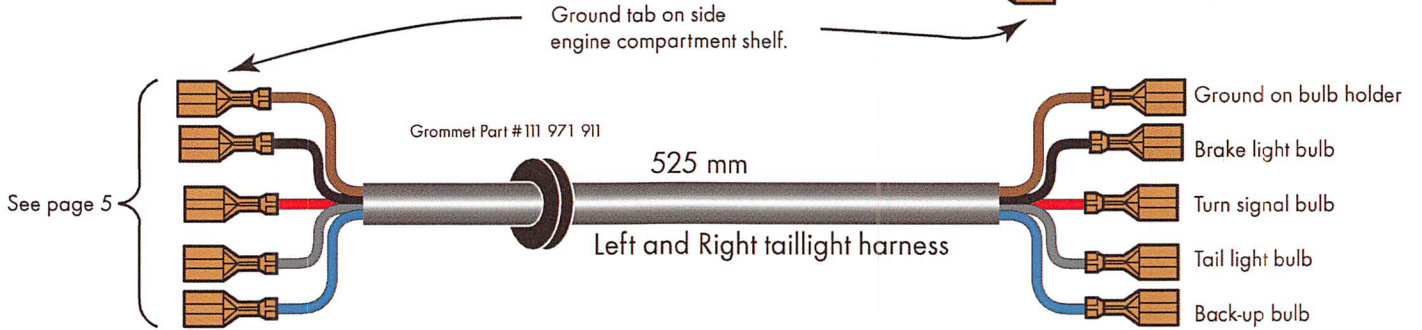
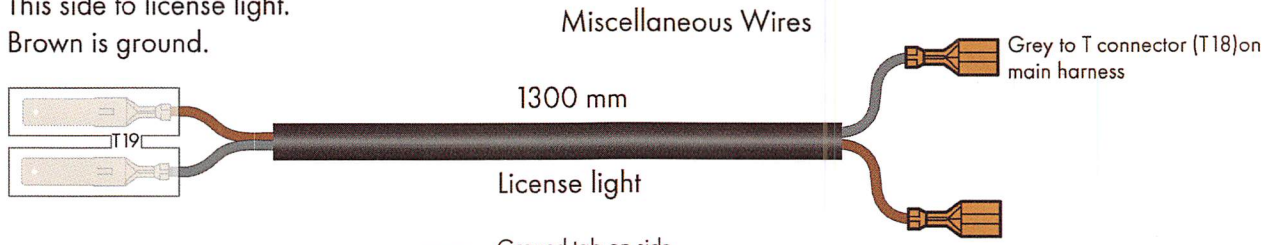



## Miscellaneous Wires, continued

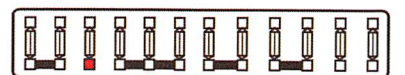
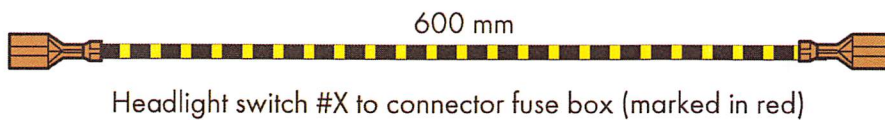
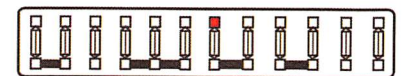
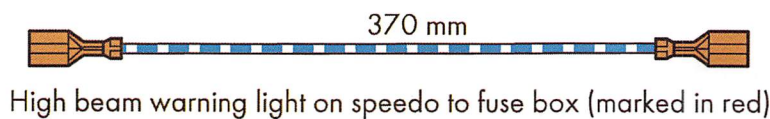
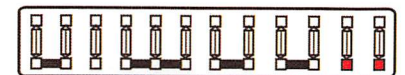
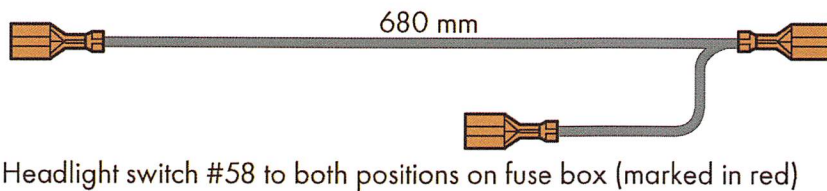
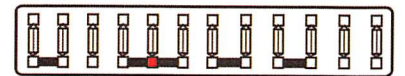
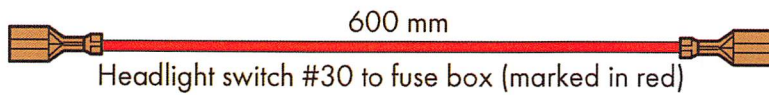
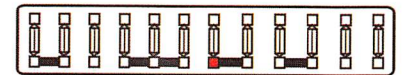
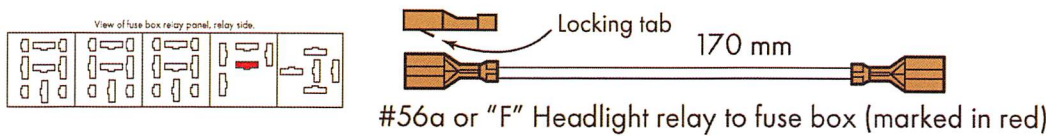
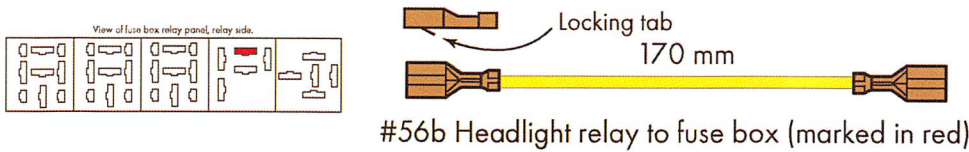
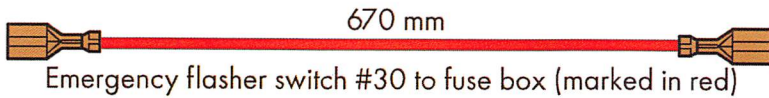
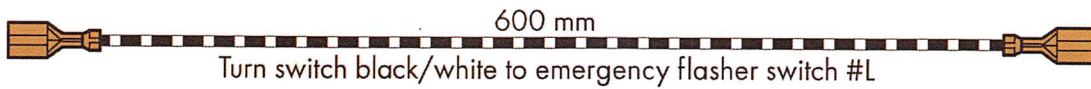
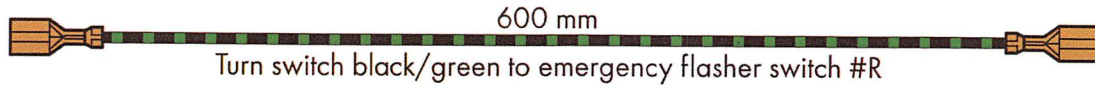
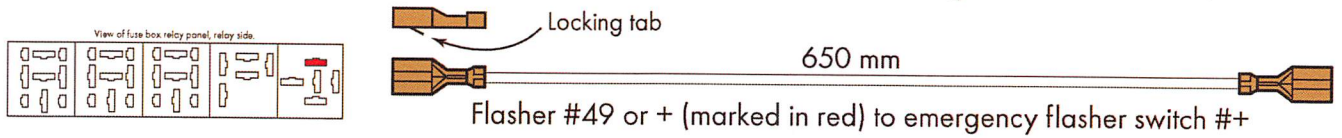
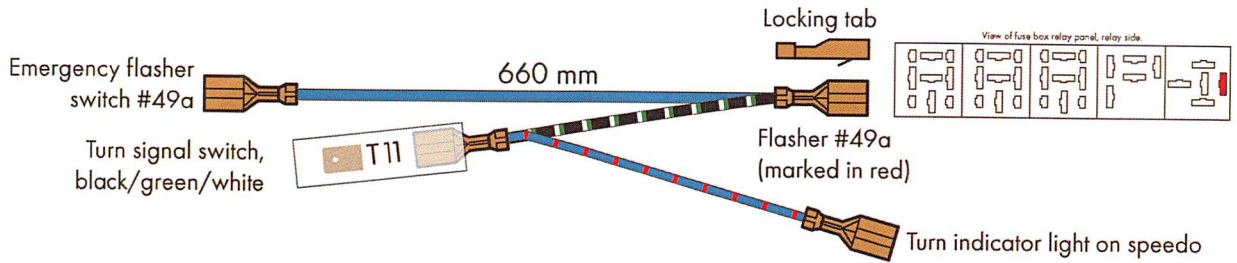

Miscellaneous Wires, continued

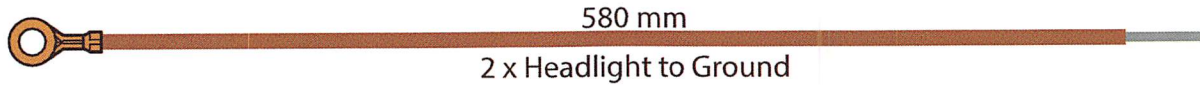
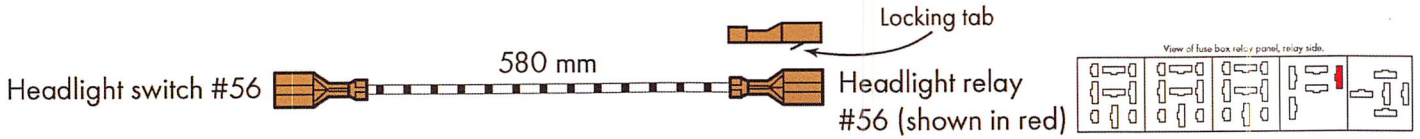

To T14 connector on main harness (red wire next to voltage regulator under rear seat) to starter #50



Dash Ground Wire Harness

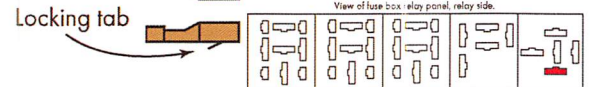

If you are running the door buzzer install the following three wires.

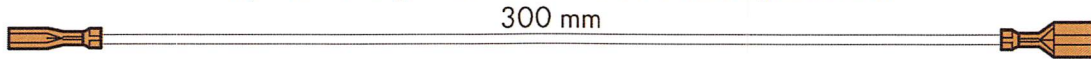

Left door post switch to connector T8, brown blue wire from ignition switch harness.

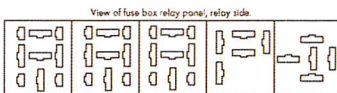

Warning buzzer #86

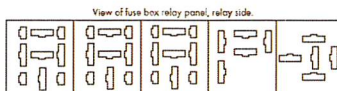

Warning buzzer #85

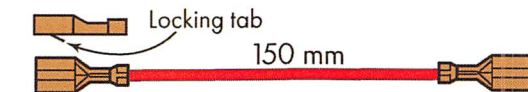

Warning buzzer #85 to fuse box (marked in red)

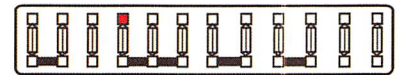

If you have a headlight relay with a #30 terminal this wire will be needed.

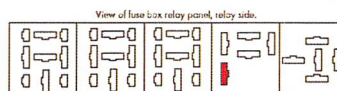

High beam relay #30 to fuse box (marked in red)

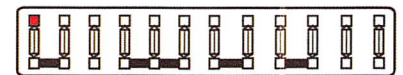
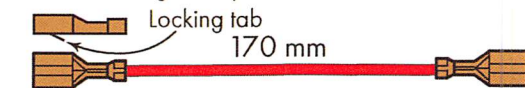



A	Battery	M4	Turn indicator, front right
B	Starter	M5	Turn indicator, rear left
C	Generator	M6	Turn indicator, rear right
C1	Voltage regulator	M7	Brake/tail light, left
D	Starter/Ignition switch	M8	Brake/tail light, right
E	Windshield wiper switch	O	Coil
F	Light switch	O1	Automatic choke
G	Turn indicator switch	O2	Idle valve cutoff
G1	Emergency flasher switch	S	Fuse box, 12 fuse
H	Horn button	S1	Back-up light fuse in engine compartment
H1	Horn	T1	Double connector, left quarter panel
H5	Ignition key warning buzzer	T2	Double connector, right quarter panel
J	Turn Signal/Emergency relay	T3	Triple connector, left quarter panel
J3	Dimmer relay	T4	Single connector, behind speedometer
J4	Stop light switch	T5	Single connector, behind speedometer
J5	Oil pressure switch	T6	Single connector, behind speedometer
J6	Back-up light switch	T7	Single connector, behind speedometer
J7	Fuel gauge sending unit	T8	Single connector, behind speedometer
J8	Brake warning light switch	T9	Double connector, behind speedometer
K1	High beam warning light	T10	Double connector, behind speedometer
K2	Generator warning light	T11	Single connector, behind speedometer
K3	Turn indicator warning light	T12	Single connector, behind speedometer
K4	Oil pressure warning light	T13	4 connector, behind speedometer
K5	Speedometer light	T14	Single connector, under rear seat
K6	Fuel gauge vibrator	T15	Single connector, behind engine sound deadner
K7	Fuel gauge	T16	4 connector, behind engine sound deadner, left
K8	Brake warning light	T17	Triple connector, behind engine sound deadner, right
L1	Sealed-beam unit, left	T18	Y connector, behind engine sound deadner, right
L2	Sealed-beam unit, right	T19	Double connector, at top of engine door
M1	Parking light, left	W	Windshield wiper motor
M2	Parking light, right	X1	Back-up light, left
M3	Turn indicator, front left	X2	Back-up light, right
		Y	Interior light
		Y1	Interior light switch, left
		Y2	Interior light switch, right
		Z	License plate light

- ① Battery ground strap
- ② Steering column to steering box ground jumper
- ③ Chassis to transaxle ground strap

